

2006 L320 HSE Suspension Issues - Resolved. Valve Blocks, Compressor.

- ▶ Information for Others to leverage from
- ▶ Car is in Ireland, it is a passenger unit (not 2-seater commercial).
- ▶ Originally Irish car, not imported as used.
- ▶ I purchased in June 2020 with 136,000kms as a 2 owner car
- ▶ (2nd owner had it for a couple of months and must have had 2nd thoughts)

Item	Problem	Issue detected Date	Other Symptoms	Items Ruled out	Root Cause	Performance after fix.	Status
1	Compressor running excessively and eventually 'orange' suspension warning light on Dashboard with message 'normal height only, special programs off'. I didn't have a diagnostics tool at this time, so don't have codes, but I suspect not achieving pressure in pre-determined time.	June-2020	<ul style="list-style-type: none"> • Would struggle to get to extended height, lot of compressor action • Slight sag in rear left corner • Does not drop height overnight • Jumps to extended height when selecting access height. 	Bags ruled out as car doesn't drop over time (checked over a full weekend). Full calibration completed	Original Compressor knackered. Diagnosed and replaced by Independent LR garage.	<ul style="list-style-type: none"> • Pumps up quickly. Launder compressor - some vibrations from housing, I adjusted it and it improved a little. • Sag in LHR corner still there 	Fixed June-2020
2	Suspension 'orange' fault. Not going up, not going down....and eventually stuck in access mode. (I call this the mountain goat effect)	Nov-2020	None really, annoying when driving around in access mode though!	N/A	Compressor knackered after 5 months. Replaced by Independent LR garage FOC.	Operating as it should Not as loud as the previous compressor. Goat has become more compliant.	Fixed Nov-2020
3	<ul style="list-style-type: none"> • Intermittently jumps to Extended mode (7 times out of 10) almost immediately after selecting Access mode. (residual issue after compressor change, was an issue before compressor change also). (I have called this the surprised cat effect) • That surprised cat issue, still annoying me after compressor change. So when in for the 2nd compressor replacement I asked independent LR garage to see if he could find anything. 	July-2020 (and maybe before)	<ul style="list-style-type: none"> • Would resolve itself after power off and on ignition and some repeated pressing of suspension height switches to get back to standard height • Sag in LH corner still there, comes and goes. Not able to figure out a pattern for this issue, but random measurement checks show it is a problem. • Diagnostics show, gallery slow to vent fault keeps reappearing after codes cleared. 	<ul style="list-style-type: none"> • Compressor already resolved • Obstructions = none • Height sensors suspected, but not throwing up any faults • Full calibration completed • Struts - did a full suspension test, no leaks on bags, shocks perfect also, verified using the suspension test machine. • Not exhaust valve as compressor is new. 	Appears to be the Valve block orings, time will tell. For may reasons, including not using different suspension heights, this issue dragged on a bit!	<ul style="list-style-type: none"> • Doing what it should when selecting access mode. • Sag gone - sits level • Not a millimetre of drop over a weekend • 1780kPA drops to 1640kPA over weekend when idle, but settles to 1720kPA when energised without compressor coming on • Cat has mellowed out a bit. 	Fixed Feb-2021

The Next few pages will go into more detail on 1, 2 & 3 above

Item	Problem	Issue detected Date	Other Symptoms	Items Ruled out	Root Cause	Performance after fix.	Status
1	Compressor running excessively and eventually 'orange' suspension warning light on Dashboard with message 'normal height only, special programs off'. I didn't have a diagnostics tool at this time, so don't have codes, but I suspect not achieving pressure in pre-determined time.	June-2020	<ul style="list-style-type: none"> • Would struggle to get to extended height, lot of compressor action • Slight sag in rear left corner • Does not drop height overnight • Jumps to extended height when selecting access height. 	Bags ruled out as car doesn't drop over time (checked over a full weekend). Full calibration completed	Original Compressor knackered. Diagnosed and replaced by Independent LR garage.	<ul style="list-style-type: none"> • Pumps up quickly. Lounder compressor - some vibrations from housing, I adjusted it and it improved a little. • Sag in LHR corner still there • Jumps to extended height when selecting access height, still an intermittent issue 	Fixed June-2020

Chapter 1 - New Compressor

I had only purchased the car and was aware of a suspension fault, but was willing to take the gamble. I didn't have much knowledge of the system. A good way to learn about something is to roll up the sleeves and fix an ongoing issue. As I was getting a few things sorted on the car I decided to hand it over to an independent LR garage to give it a good going over and tackle some jobs best left to the experts and to speed up the process. Timing belts, Oil Pump, Full fluid change, filters etc and that suspension issue. Turns out the suspension issue was a quick diagnosis to the compressor, and after weighing up the option to repair Vs Replace, it seemed like a good idea to replace considering countless posts from others indicating the new compressor is supposed to be a bit beefier!

The LR guy did some basic due diligence on rest of suspension system, without pouring hours into it and subsequently having to hand me a large bill for manhours - we both agreed this was an appropriate approach considering the fundamental root cause of a knackered compressor was evident. Nothing suspicious came up during the due diligence, and he did a comprehensive calibration on the system afterwards. We had some phone calls after I got the car back about the noisy compressor and intermittent jumping to extended height. I was back at the garage for some clarification on the noise issue, he seemed to think it was about normal and we discussed dropping the car back for a review of suspension system for the other issue for jumping to extended mode when selecting access height. As this was an intermittent issue, and I wasn't really using the suspension heights for anything between Jul-Nov, and I was busy with many other things I did not return to garage for some time. I spent a little time learning a bit more about how the system worked, but then the issue Number 2 occurred in ~November timeframe.

Jump to next page for chapter 2!

Item	Problem	Issue detected Date	Other Symptoms	Items Ruled out	Root Cause	Performance after fix.	Status
2	Suspension 'orange' fault. Not going up, not going down....and eventually stuck in access mode. (I call this the mountain goat effect)	Nov-2020	None really, annoying when driving around in access mode though!	N/A	Compressor knackered after 5 months. Replaced by Independent LR garage FOC.	Operating as it should Not as loud as the previous compressor. Goat has become more compliant.	Fixed Nov-2020

Chapter 2 - Another new Compressor

So in the course of my learning journey on the suspension, I was selecting access height and the extended mode appeared in typical fashion and fault code with the addition of the 'orange' suspension warning - the warning light was something I hadn't seen for a few months. Anyways, I switched the car off and back on again, and unusually the warning came back. I decided I would remove the suspension fuses for a while to see if the controller needed a little holiday and the rest would put it in good humour. That idea proved nothing more than my suspension controller was a true hard working honest member of the team and it did not need a holiday and it was only offering me a true system status as the orange light persisted following re insertion of the fuses.

I was in a jam, stuck in access mode, journeys were not the plush and enjoyable wafting along that I was now used to, and rather reminded me of times in my early 20's when I travelled in my mates car that had some dodgy aftermarket suspension work done.

It was time for a trip to LR Specialist.

I was expecting a result of a gimped height sensor and a final resolution to the overall suspension issues to include the varying heights and intermittent rear left sag. Nope!, rapid diagnosis, the 5 month old compressor was knackered.

New compressor installed, let's roll onto Chapter 3.

Item	Problem	Issue detected Date	Other Symptoms	Items Ruled out	Root Cause	Performance after fix.	Status
3	<ul style="list-style-type: none"> Intermittently jumps to Extended mode (7 times out of 10) almost immediately after selecting Access mode. (residual issue after compressor change, was an issue before compressor change also). (I have called this the surprised cat effect) That surprised cat issue, still annoying me after compressor change. So when in for the 2nd compressor replacement I asked independent LR garage to see if he could find anything. 	July-2020 (and maybe before)	<ul style="list-style-type: none"> Would resolve itself after power off and on ignition and some repeated pressing of suspension height switches to get back to standard height Sag in LH corner still there, comes and goes. Not able to figure out a pattern for this issue, but random measurement checks show it is a problem. Diagnostics show, gallery slow to vent fault keeps reappearing after codes cleared. 	<ul style="list-style-type: none"> Compressor already resolved Obstructions = none Height sensors suspected, but not throwing up any faults Full calibration completed Struts - did a full suspension test, no leaks on bags, shocks perfect also, verified using the suspension test machine. Not exhaust valve as compressor is new. 	Appears to be the Valve block orings, time will tell. For may reasons, including not using different suspension heights, this issue dragged on a bit!	<ul style="list-style-type: none"> Doing what it should when selecting access mode. Sag gone - sits level Not a millimetre of drop over a weekend 1780kPa drops to 1640kPa over weekend when idle, but settles to 1720kPa when energised without compressor coming on Cat has mellowed out a bit. 	Fixed Feb-2021

Chapter 3 - Getting Stuck in

So having a second compressor in short succession elevated my motivation to sniff out the Root cause for above issues. My independent LR guy is dependable, and I didn't have to ask if the replacement compressor was going to be FOC, he just said it was unacceptable and was not unheard of that a compressor can fail soon after install. I am a little more inclined to think the problem may be 2-fold, and that there is a more fundamental issue that is not helping the run time on compressor and that issue needs to be found!

Right, as it was in the garage waiting for new compressor delivery and I was driving a 1.0L diesel Fabia as a loan car, I decided it was prudent to have the LR guy rule out some items before I took over the investigation. I asked him to verify the height sensors were good, that there were no leaks and that the struts were good. He sent the car to local truck test centre to complete a comprehensive test on the struts. A clean bill of health was issued on all 3 items. I said I would take over the investigation from here as the rest would take time! I started by looking for leaks, and getting eyes on the individual components of the system. All looked good. I also used my Icarsoft LR11 (new toy), to read codes and check system data. The only issue that keeps coming up is the code for gallery venting to slowly. I knew this was not the exhaust valve as the compressor was new.

I would start up car, the compressor would run, I would measure all corners. I was doing this on different days and sometimes doing it after car was idle without starting it. Heights were never the same, always varying slightly, range of deltas could be 5-15mm. Never really made sense, and I wasn't really that systematic in my approach, predominantly as I have young kids and you never really get an hour to sit down and work out a plan.

Anyways, I had done enough research at this point to lead me to want to rule-out the 3 valve blocks. So I ordered a set of O-rings from the US, why from the US, well Brexit was a bit of a dose, so I was curious how long delivery of a package would take from US, 4 weeks as it turns out. I did all 3 valve blocks one evening, starting at front, then rear, then middle. Front was easy peasy, access is good and the Orings went in relatively ok but I was not satisfied with the size of some of the Orings. The smallest ones were too small in comparison to original and others were too big.

continued next page.....

Chapter 3 Continued - Getting Stuck in

Moving to the rear valve block, I had read about how hard it was to get the block out, and some guy accessing the 2 rear airline connections from underneath by removing the spare wheel - that is not necessary, or indeed possible on the RRS. What I found, with car jacked up and sitting on axle stands, that with the correct technique the valve block is not that much of an issue to remove. I will add some photos and detail on that later on in this document. Back to the Orings, I could not put the two pieces that you twist lock back together on the Left and right valves - it was obvious that the Orings were just too big. I ended up rigging a solution in the bench vice with rags to cushion parts and to twist the two parts with pliers using cloths to limit damage. I also had to put some original Orings back in because some were missing and the other was way too big!
continued next page.....

I then tackled the middle valve block and had all 3 valves back in the car by midnight. Turned on the car, pressurised the system and suspension raised to standard height pretty quickly, definitely faster than before.

A couple of notes at this stage.

- I used Thread lock on the Voss threads (Loctite Blue 243). I did this because some guy on a forum said it was a good idea when reusing old voss connectors. **Don't do this.** I read the loctite literature after crime was committed and noticed that it is not recommended for plastic. Also, I noticed when removing the voss connector afterwards, and hoping to vent the system before reaching the end of the thread, that the loctite does it's job by preventing leaks and hence you have the voss connector at the end of it's open thread before venting starts - dodgy with 16bar!
- There was no evidence of white powder from dryer beads. Valve blocks were pretty clean, but original (so 15years service).
- Original O-rings were flattened and a little hard, so were definitely past end of life. Also some of the valves appeared to be stuck, so I suspect were not moving as freely as they should have been in normal operation.
- Pressure started to drop steadily after the valve blocks were installed and system was pressurised. I waited for 15mins or so with the live data on icarsoft. Then went to bed.
- Use a silicone grease to 'dampen' the Orings, I used ACC Silicones SGM494 Silicone Grease.
- Clean all surfaces, ensuring no dirt particles get onto Orings or mating surfaces

Next day, went into my garage and car was on the rear bump stops while front was where I left it. I wasn't surprised tbh, as those orings were crap. I switched on the car, compressor kicked in and it was at standard height in less than 5 seconds. I let it reach pressure, 1780kPa and then switched off car and started listening for leaks. I didn't hear any, so I checked the voss connections with some soapy spray both at the rear valve block RVH000055 and middle valve block RVH000046, all good. I took measurements at 4 corners and let it settle for a few hours, and it was pretty much on rear bump stops after 5 hours. I let it settle some more and took measurements at front and noticed it was dropping after the rear had dropped. So I then re-pressurised the system and moved fuses 3 and 26. The reason for removing the fuses (I remove both as I am not sure which one ultimately stops the controller) is to stop the auto-levelling system correcting the suspension when car is idle. If there was a leak on one corner, then I would know that after leaving the car alone without its fuses for some time. After 24 hours, the front hadn't budged, but rear was on the bump stops. I have checked at various period through the 24 hours and noticed the rear was dropping evenly. I had by this stage, ordered a new Bearmach valve block and a new set of seals from UK supplier 4X4Airseals. I also had a few emails with the US supplier, who said I was the only one that had found issue with their seals, so we both decided maybe a replacement set might be in order and the the set he sent me had slipped the quality control net. I wasn't convinced.

Looking at schematics and system descriptions a bit further I now understand that the centre valve in both front and rear block is closed when de-energised, the purpose of this valve is to balance the air flow between left and right valves which each serve the individual left and right air springs. The fact that the car was dropping the rear evenly suggested the Orings were not doing their job.

continued next page.....

Chapter 3 Continued - Getting Stuck in

New valve block arrived, I whipped out the old one and popped in the new one. I removed the old Voss connections from the air lines and pushed the air-lines into the new pre-torqued voss connections. This was definitely a lot easier than spanning the old ones on in situ. Turned on the car, got system re-pressurised, check for leaks took measurements and left it overnight. Next morning, all was well. Not a millimetre of movement anywhere. Did a cycle of off road height and then to access and back to Normal. No issues. Left it for 24 hours, checked measurements. Not a budge. And, the little lean/sag to Left rear corner was gone! Nice.

Time for suspension to move from one height to the next is very fast indeed, I never timed it before but it is very noticeable how quickly it reaches the position selected.

System pumps to 1780kPA, then when left overnight it settles to 1650kPA, it doesn't appear to keep dropping over time past this value. Now I understand this is reading of pressure in the reservoir, however I can guess if the Middle valve block Oring is passing a little, this might also indicate pressure in system to the next valve blocks, and if they have a little passing of air across their o-rings then the pressure may read across those also! Anyways, conspiracy theory aside for the moment, I can confirm that when I restart the car, and the middle valve block energises that the system pressure indicated is 1720kPA, and the compressor has not energised to cause increase from 1650kPA. I think we have a perfectly acceptable operating air suspension system now. At least it's good enough for me....for now.

I also stripped the original valve block again and replaced the crap Orings with the ones I got from reputable supplier 4X4 Air seals. Chalk and Cheese comparison, I will add some photos of the differences, but in short, then 4X4Airseals Orings went in perfectly they had supplied very clear instructions for somebody that is not familiar with what to do and they even pop in a little sachet of Silicone Grease! You can tell there is a proper engineer behind these seals with the way the sketches are provided and the hand written text is per how you are thought in Technical Drawing back in the day! These guys sell on ebay, I cannot recommend them enough, as simply I think you should only need to do this job once. I will now need to follow up and replace the seals in the front and middle valve blocks as I know the US ones that are in there are crap - and these will cause me bother. In advance of doing that however, I will need to get some Voss connectors seeing as I have made a mess of the original ones with the loctite mistake!

All is working as it should now, but let's see how time determines the true outcome.

Maybe there are more hidden issues that created a perfect storm and I have only uncovered part of them.

Certainly for now all appears well.

Flick onto the next few pages to see what I have learned about the system and for some photos of things I found along the way - they might help you.

The US company, well, we had many emails. They tried to make out I was the only living customer with the issue, and it was my opinion (despite the photos with Vernier measurements) and that I had selected a replacement set as the solution and therefore should not expect a refund. Long story short, I got a refund for the part, but not the shipping. Crap, but what do I do. I have more pressing matters to spend my time on.

Also, look up this document and read it. Then keep it for reference.

['Land Rover factory D3 air suspension description.pdf'](#)



What did I Learn

Valve Blocks, how they work in principal.

- ▶ Rear and Front Valve Blocks look the same are different part numbers RVH000055 and RVH000095 because of orientation of connections, and maybe some other reasons that are not apparent to me.
- ▶ Reservoir and Compressor Feed the Middle valve block on separate connections, the Pressure sensor is on the Reservoir side, so then the valve is close you are reading reservoir pressure only. 2 other connections feed the front and rear valve blocks.
- ▶ The middle valve block has one valve, so when it opens it effectively opens the lines between front and rear valve blocks and the compressor and reservoir. A crude view is, that reservoir will overcome pressure requirements in the system until it can't, then the compressor kicks in.
- ▶ Front and Rear valve blocks operate on same principal. There are 3 valves in each of these blocks, 2 corner valves and 1 crosslink valve (middle). Corner valves control the flow of air in/out of individual air springs and the cross link provides the connection between the 2 springs on each axle. When de-energized all 3 valves close in the block, meaning when you whip out the system fuse you should be able to zone in on a leak pretty quickly as the self levelling is disabled.

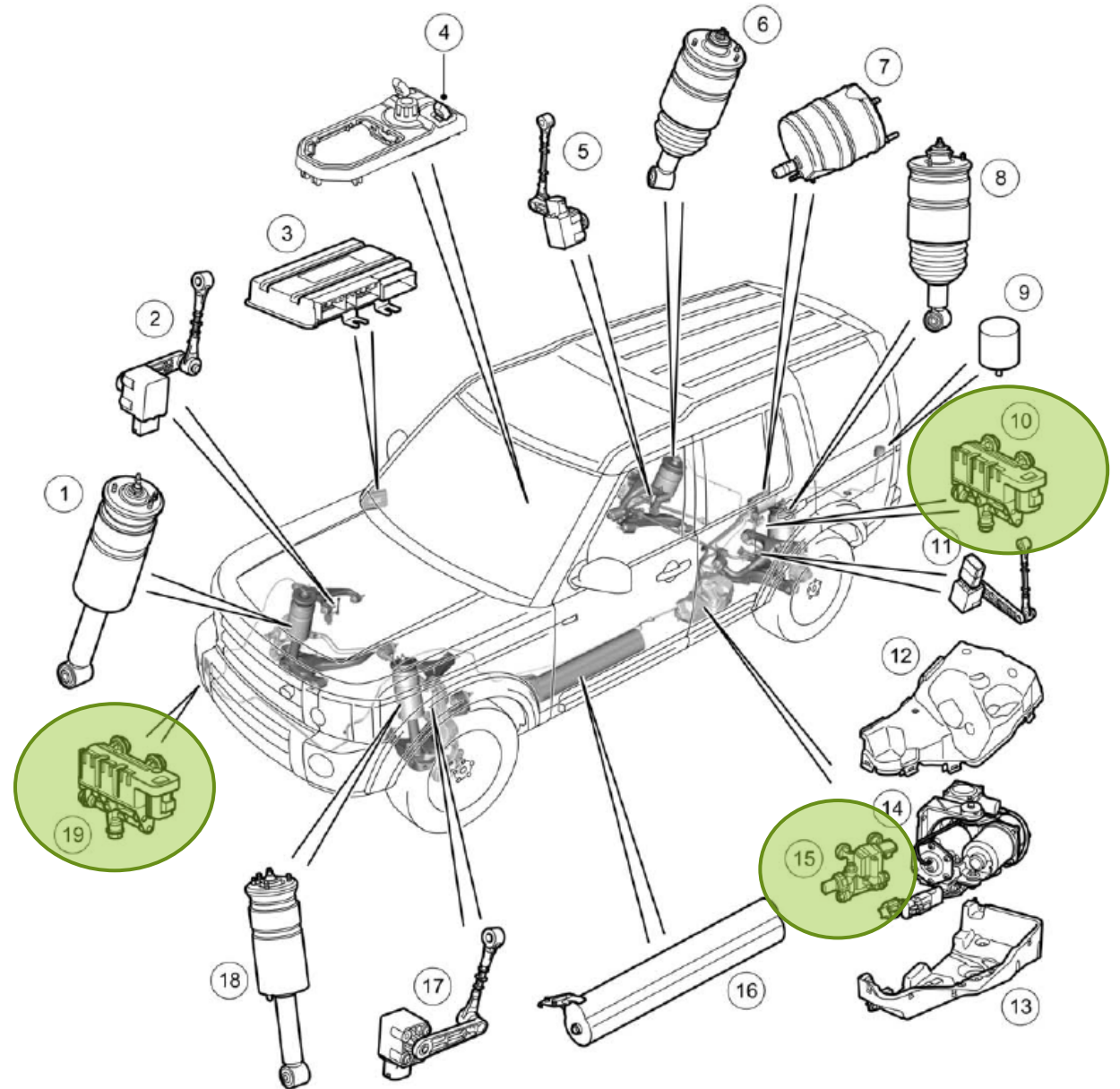

What did I Learn

Valve Block

Front Valve Block is easy to work on, accessed by peeling back wheel arch liner and removing front RHS wheel for more access.

Middle one valve is also easy to access, drop the compressor cover and work away!

Rear Valve block is also easy with appropriate method. I will give you some photos of how I did it. On next page.

Crack open the connections, and once air is heard venting, let the pressure dissipate before removing the Voss completely - 16Bar!

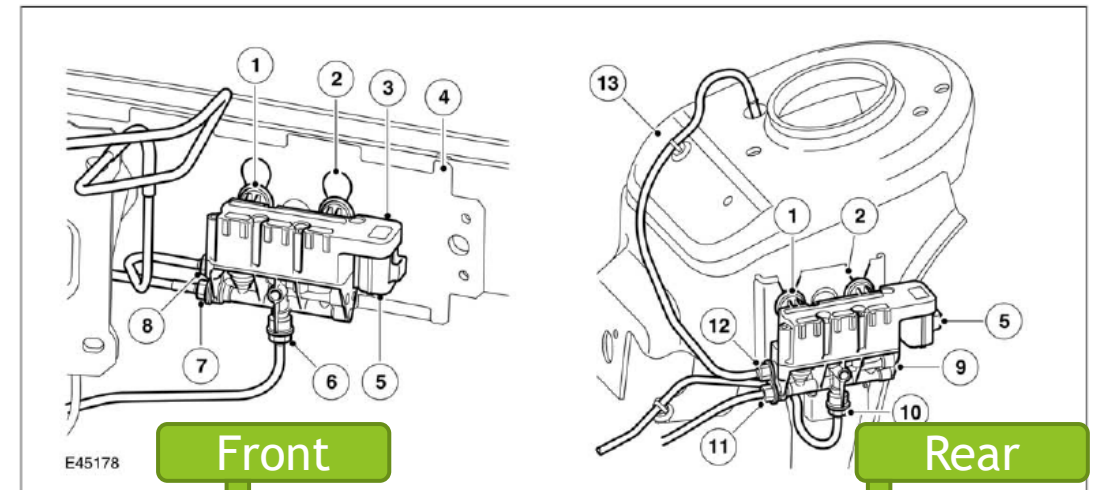

What did I Learn

Rear Valve Block

Put car in access mode, then lock suspension by holding the button down until lock symbol appears and you get the friendly message confirming status.

Jack car up and support on axle stand. Take off rear left wheel, and you will see the valve block where my black/red screwdriver is in the photo 1.

Remove electrical connector and pop the valve block upwards out of the mounting position so it is free from mount. This will give you room to get your 12mm spanner onto the bottom Voss connector per photo 2. Photo 3 shows the connector removed.

Rotate the valve block backwards by 90degrees. This will give you access to the remaining 2 voss connectors per photo 4. Follow the anchor points a and b through the photos, this should help you figure out what way the camera is pointing as it may not be clear when looking at photo 4 in isolation.

That's it - you're done. Install is reverse sequence of above steps. If you have new voss connectors, then see details further on in this document.



What did I Learn

The Orings

As I mentioned earlier, the supplier I would recommend is 4X4Airseals.com (UK supplier). I will compare the correct seal with those supplied from company in US to give you an idea of how much of a problem it was.

I am not going to get into how to install the Orings as others have done an excellent job on that with Youtube videos etc and you get instructions from the company mentioned above. I have no affiliation whatsoever with them, I just think people that do a good job deserve to be promoted.

Screwdriver always points to the correct Oring.

Photo1, 2 & 3 - Correct seal is the bigger one, the green one was supplied blue company in US

Photos 4, 5, 6, 7 show comparison of other Oring, and how it wouldn't seat correctly. Photos are self explanatory. There were issues with all Orings, but I chose these 2 to compare here.

Photo 8 - Use Silicone Grease on the Orings - sparingly!

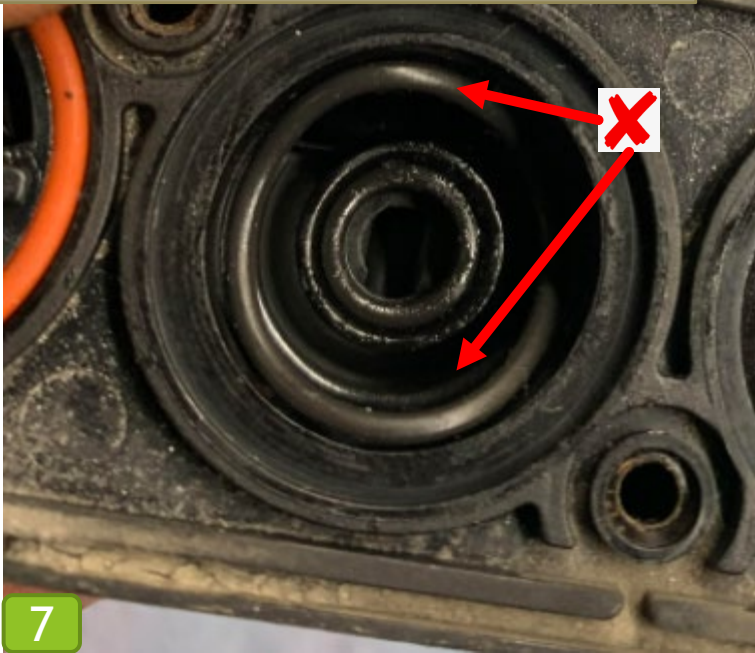
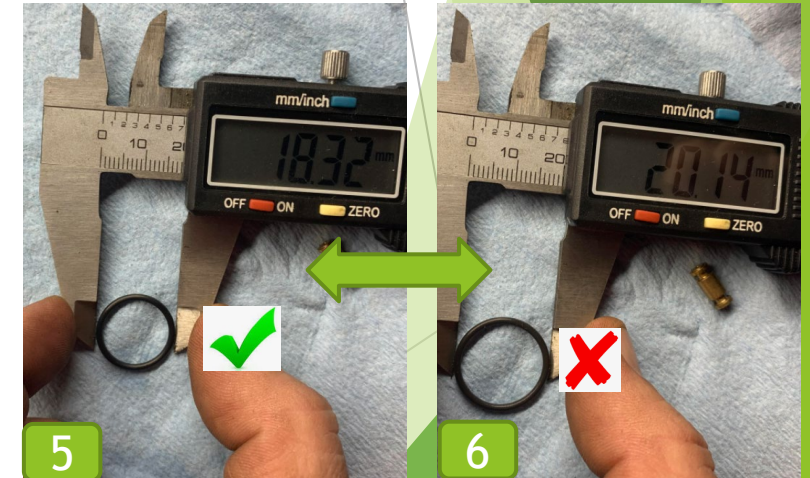
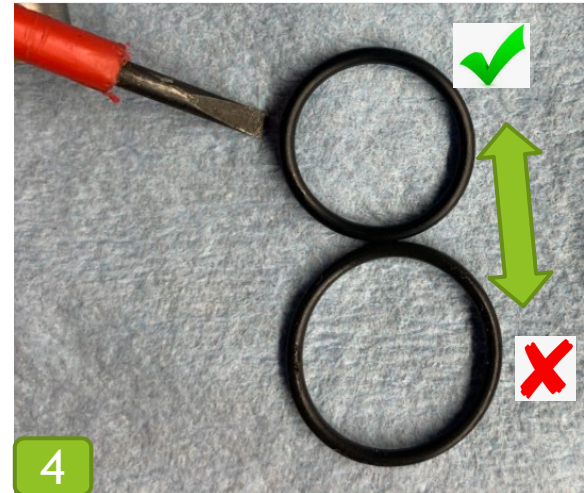
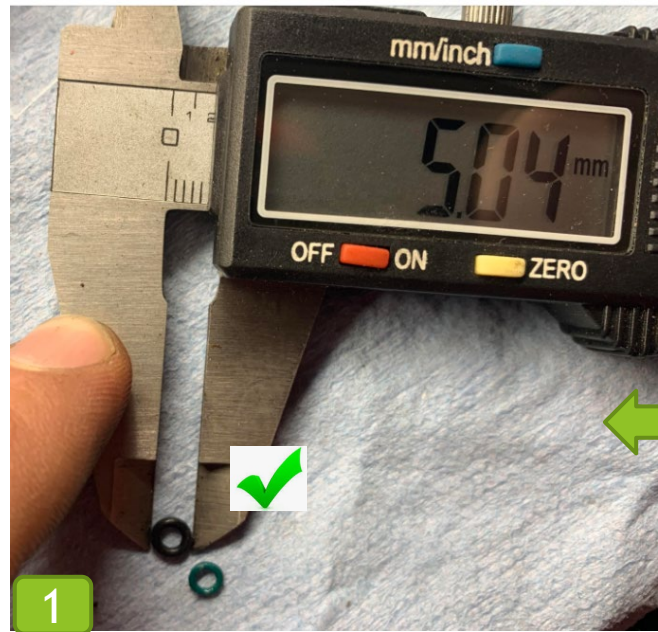

What did I Learn

The Orings - the M'Fu\$ker!

This is the one I mentioned earlier. It was a pig.

There is just one O-ring for this position, but I put both on for comparison photo. As you can see the crap one is massive in comparison (too thick). You can see it has even deformed from 48 hours under severe compression.

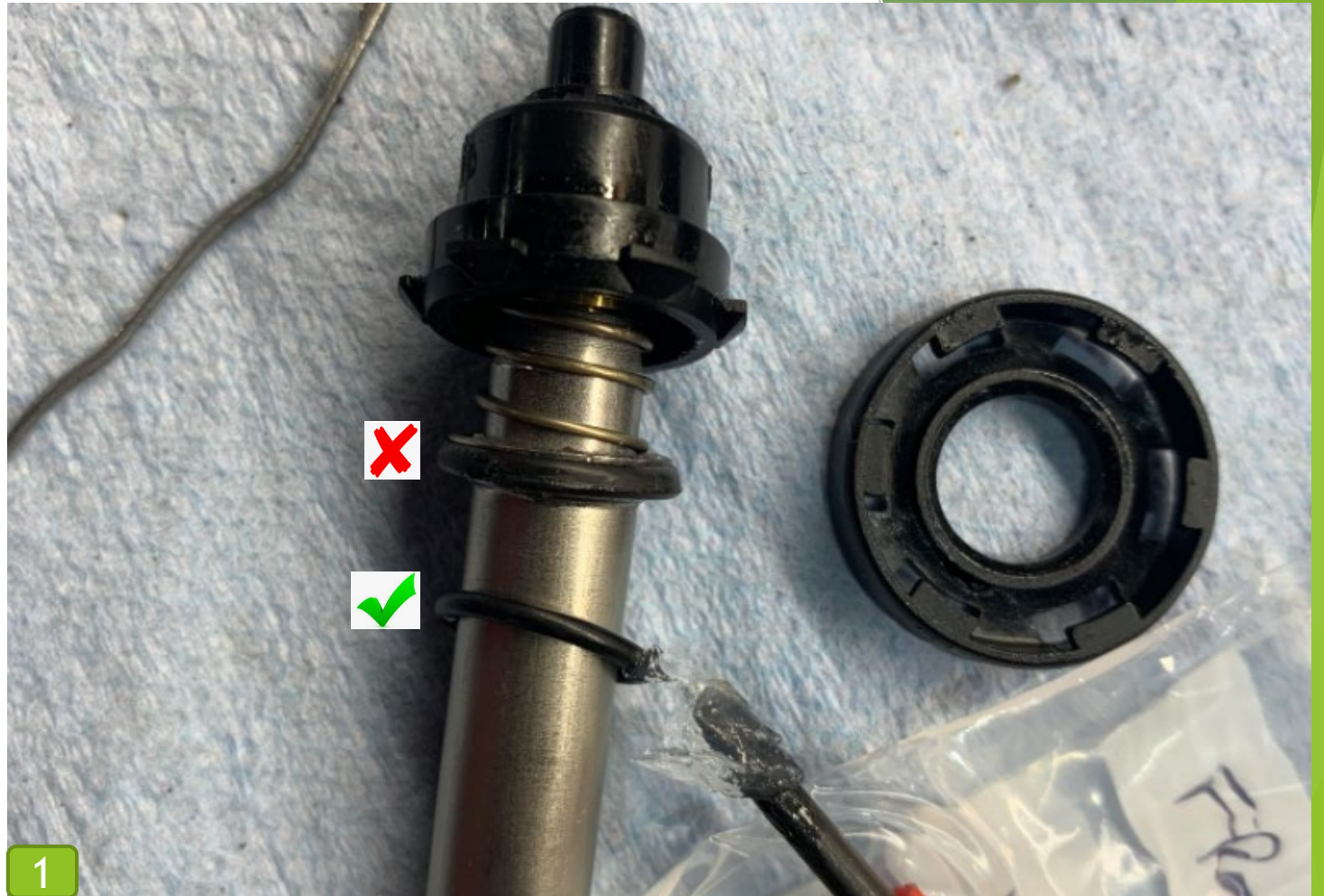

What did I Learn

Using the new Voss connectors supplied on New Valve block

If you have new Voss connectors, I recommend using them. It is easier to connect the tubing to them in Situ rather than screwing on old connectors with a spanner and trying to apply 3Nm of torque, which is very small btw!

Photo 1 - Push the Threaded connection back to reveal the inner split ring and rotate the ring so you can see it. Gently widen the split with a flat faced screwdriver and remove the split ring.

<https://www.youtube.com/watch?v=sEZppy7bqpk>

Photo 2 & 3 - remove the threaded voss connector and inspect and clean up the tube.

Photo 4 - 3 airline voss connectors removed at rear valve block location.

Photo 5 - add a little silicone grease to the Orings inside the new Voss connectors.

Photo 6 - push the tube home into the Voss connector, you will feel a click, and then pull the tube back out to make it grip into the split ring. My advice for the Rear valve block, is use the reverse install sequence mentioned earlier and valve block rotated up 90 degrees from the home position. i.e. start with the green tube, LH rear spring connection, then the main supply air and finish with the RH rear spring connection.

Ensure you have a good grip of the valve block and tube BEFORE you start pushing it in, you don't want to find it grips on the split ring before the tube is pushed fully home.

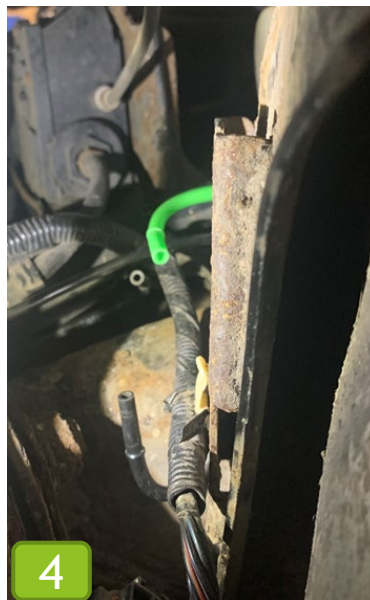
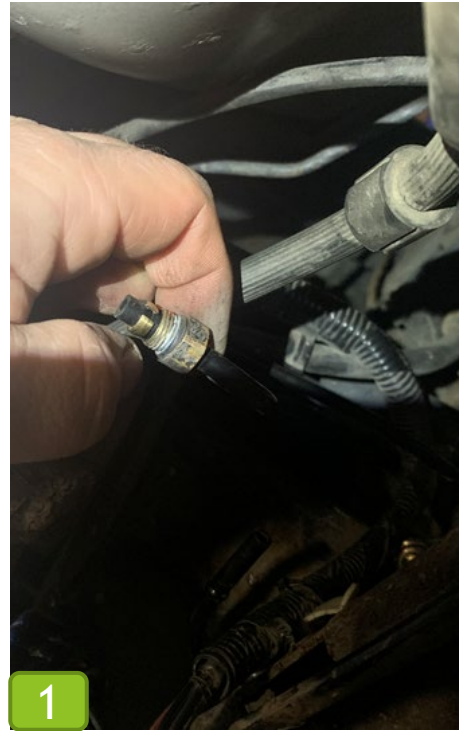

What did I Learn

Filter & Silencer

It is doubtful these will ever be your problem. The intake filter, item 3, is inside the car so unless you live in a dusty desert and the inside of your car requires a shovel to clean it out rather than a vacuum cleaner I think you will be ok.

The silencer - well....I think this will generally be ok too. It provides attenuation duties for both supply and exhaust air.

Interestingly, the exhaust air line (larger diameter pipe), item 1, runs from the silencer back to discharge right beside the compressor.

Air Intake Assembly

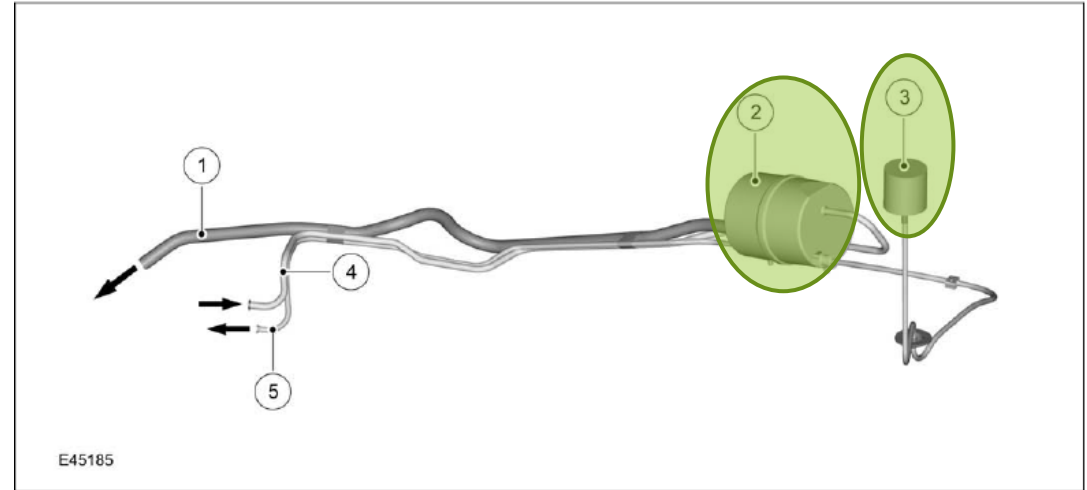

Item	Description	Item	Description
1.	Exhaust to atmosphere	4.	Exhaust air from air supply unit
2.	Inlet and exhaust silencer	5.	Air inlet supply to air supply unit
3.	Air inlet filter		