

Valve Block Filter (60.60.21)

Removal



CAUTION: Dynamic Response system components are manufactured to very precise tolerances and fine clearances. It is therefore essential that absolute cleanliness is observed when working with these components. Always install blanking plugs to any open orifices or lines. Failure to follow this instruction may result in foreign matter ingress to the Dynamic Response system.

NOTE:

This procedure does not require the Dynamic Response system to be bled.

1



WARNING: Do not work on or under a vehicle supported only by a jack. Always support the vehicle on safety stands.





Raise and support the vehicle.

2



CAUTION: Before disconnecting or removing the components, ensure the area around the joint faces and connections are clean. Plug open connections to prevent contamination.



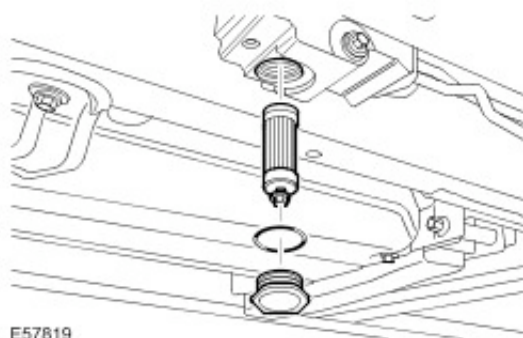

Remove and discard the valve block filter.

-  Position container to collect fluid loss.
-  Remove the access plug.
-  Remove and discard the access plug O-ring seal.
-  Using a suitable M6 bolt, release the filter from the valve block.



Installation

1 . Install the new valve block filter.

-  Clean the component mating faces.
-  Install a new access plug O-ring seal.
-  Tighten the access plug to 62 Nm (46 lb.ft).
-  Remove the container.

2 . Start the engine and allow to idle.

3 . Check and top-up the Dynamic Response system fluid reservoir.