

Wheels and Tires

GENERAL

A number of alloy wheel and tire size combinations are available. A Tire Pressure Monitoring System (TPMS) is also available. This system monitors the pressure in each tire and informs the driver if the pressure is outside predetermined thresholds.

WHEELS

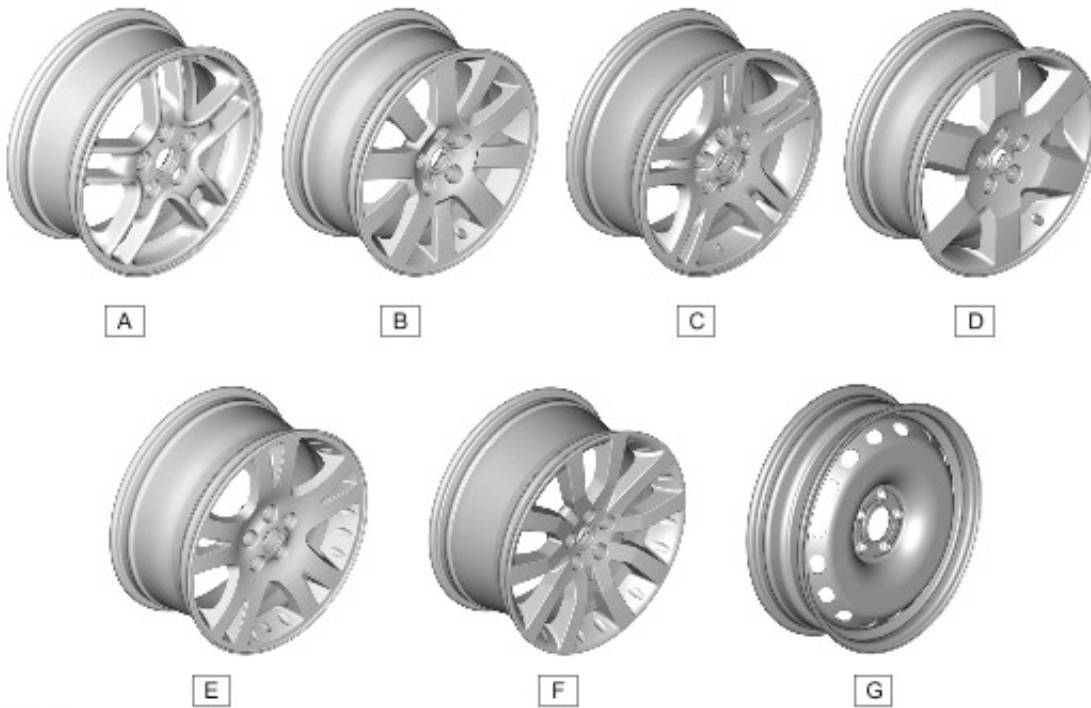

E52479

Item	Part Number	Description
A		7JX17
B		8JX18 - Style 2
C		8JX18 - Style 3
D		8JX19
E		9JX19
F		9½JX20
G		5½JX19 - Space saver

There are a number of different alloy wheel sizes and styles as shown in the above illustration.

The spare wheel fitted to most vehicles is a steel space saver wheel. The wheel size is 5½J X 19 and uses a T175/80R19 tire. The space saver wheel is a standard fitment for all markets except Gulf states. An 8J X 19 alloy, black painted spare is offered as an optional fitment. The steel space saver and the alloy spare wheel are subject to a maximum 50 mph (80 km/h) speed limit.

TIRES

Tires are available in a number of sizes and tread patterns dependent on the vehicle usage. Tire sizes are as follows:

- 235/65R17
- 255/55R18
- 255/50R19
- 275/40R20.

The following tires are available; All Season (AS), All Terrain (AT) and All Terrain - Sport (AT-S).

NOTE:

Tires should be inflated to the recommended pressures (as given in the owners handbook) only when the tires are cold (ambient temperature). If the tires have been subjected to use or exposed to direct sunlight, move the vehicle into a shaded position and allow the tires to cool before checking and/or adjusting the pressures.

Tire Changing

Care must be taken when removing and refitting tires to ensure that the tire pressure sensor is not damaged.

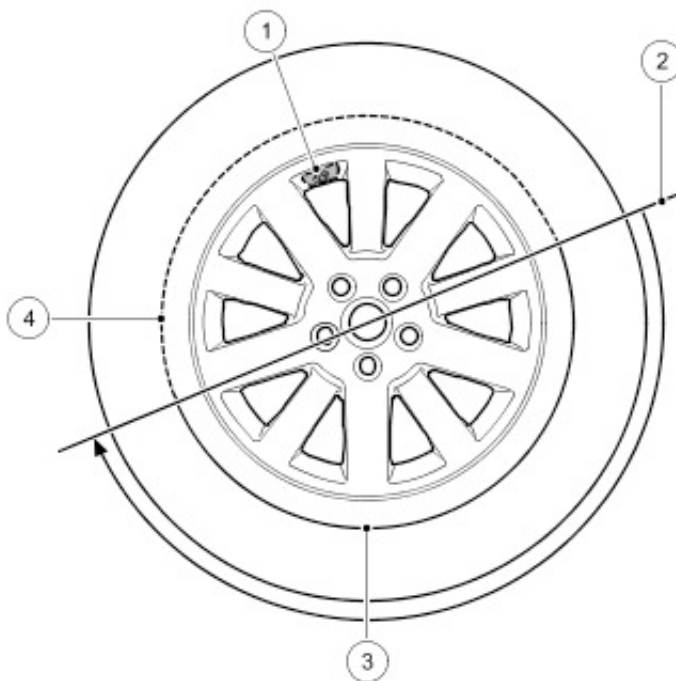

E45549

Item	Part Number	Description
1		Tire valve and pressure sensor
2		Tire fitting/removal tool initial start position
3		High tire and bead tension area
4		Low tire and bead tension area

When removing the tire, the bead breaker must not be used within 90 degrees of the tire valve in each direction.

When using the tire removal machine, the fitting arm start position must be positioned as shown in the tire changing illustration. The wheel can then be rotated through 180 degrees in a counterclockwise direction. This will relieve the high tension from the tire bead allowing the remaining 180 degrees of the tire to be manually pulled from the rim.

When refitting the tire, position the fitting arm as shown. Rotate the tire and take care that the bead on the low tension side of the tire does not damage the sensor.

Tread Act - NAS Only

Vehicles supplied to the North American markets must comply with the legislation of the Transport Recall Enhancement, Accountability and Documentation (TREAD) act. Part of the requirement of the TREAD act is for the vehicle to display a label, positioned on the driver's side B-pillar, which defines the recommended tire inflation pressure, load limits and maximum load of passengers and luggage the vehicle can safely carry. This label is specific to each individual vehicle and is installed on the production line.

This label must not be removed from the vehicle. The label information will only define the specification of the vehicle as it came off the production line. It will not include dealer or owner fitted accessory wheels and tires of differing size from the original fitment.

If the label is damaged or removed for body repair, it must be replaced with a new label specific to that vehicle. A new label is requested from Land Rover parts and will be printed specifically for the supplied VIN of the vehicle.

TIRE PRESSURE MONITORING SYSTEM (TPMS)

Tire Pressure Monitoring System - Component Location

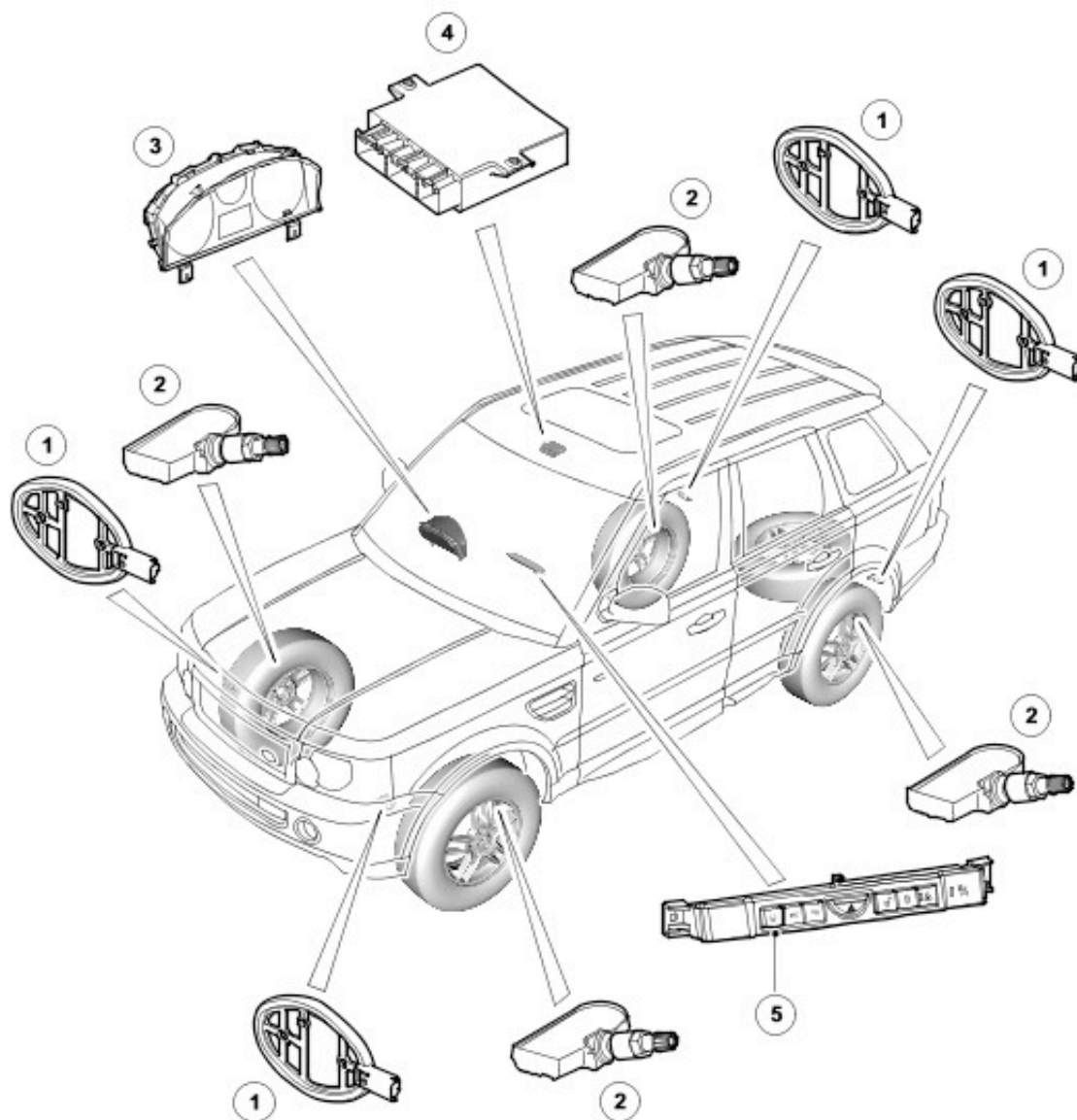

E52480

Item	Part Number	Description
1		Initiator
2		Tire pressure sensor
3		Instrument cluster
4		TPMS module
5		TPMS switch (Not available on NAS vehicles)

The purpose of the Tire Pressure Monitoring System (TPMS) is to assist the driver in maintaining the vehicle's tire pressures at the optimum level in order to:

- improve fuel consumption
- maintain ride and handling characteristics

- reduce the risk of rapid tire deflation – which may be caused by under inflated tires
- comply with legislation in relevant markets.

The TPMS measures the pressure in each of the tires on the vehicle (including the spare, if required) and issues warnings to the driver if any of the pressures deviate from defined tolerances.

NOTE:

During a 'blow out' a very rapid reduction in pressure is experienced. The system is not intended to warn the driver of a 'blow out', since it is not possible to give the driver sufficient warning that such an event is occurring, due to its short duration. The design of the TPMS is to assist the driver in keeping the tires at the correct pressure, which will tend to reduce the likelihood of a tire 'blow out' occurring.

A single TPMS hardware configuration is used. TPMS status information is relayed to the driver with a message displayed in the instrument cluster message center and one warning indicator LED.

The message center provides the driver with more detailed information and identifies of location of a specific tire on the vehicle.

TPMS Module

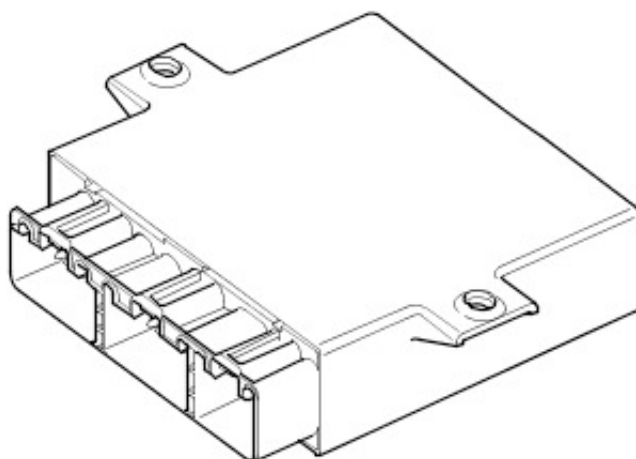

E45551

The TPMS module is located above the headlining of the vehicle, mounted in a central position above the windscreen. The module is retained in position with two plastic locknuts. The three connectors of the module point towards the left hand side of the vehicle.

The TPMS module's main function is to detect the following:

- the tire pressure is below the recommended low tolerance value – under inflated tire
- the tire pressure is below the recommended lower tolerance value – significantly under inflated tire
- the location of the tire on the vehicle.

The TPMS module also communicates with the vehicle instrument cluster to provide the driver with appropriate warnings that show the importance of the condition detected and indicate the status/failure of TPMS components.

Tire Location

Because of the requirement for different pressure targets and thresholds for the front and rear tires, the TPMS module can identify the location of the tires on the vehicle, and assign a received tire pressure sensor identification to a specific position on the vehicle (i.e. FL (front left), FR (front right), RL (rear left) or RR (rear right)).

Tire location is performed automatically by the module using an auto-location function. This function requires no manual intervention by the driver. The TPMS module can automatically learn the position of tires on the vehicle if the tire pressure sensors or their positions are changed on the vehicle.

The TPMS module can automatically detect, under all operating conditions, the following:

- one or more tire pressure sensors have been replaced
- one or more tire pressure sensor identifications are missing
- one or more 'alien' identifications are being received, i.e. the module can reject identifications from tire pressure sensors that do not belong to the vehicle
- the spare tire and one of the tires in use on the vehicle have exchanged position on the vehicle.

If the tire pressure sensors fitted to the vehicle are changed, the module can learn the new sensor identifications automatically. The learn function requires no manual intervention by the driver.

If a new sensor is fitted to the spare tire, it must have its identification code programmed into the TPMS module diagnostically using T4 or the used on the vehicle as a 'running' wheel and the vehicle driven for 15 minutes at more than 12.5 mph (20 km/h).

Spare Tire Identification

Depending on the vehicle specification, the spare tire may or may not be fitted with a tire pressure sensor.

NOTE:

Tire pressure sensors cannot be fitted to steel space saver spare wheels.

If the spare tire is fitted with a tire pressure sensor, the TPMS module can detect it, determine that it is the spare tire and monitor its pressure and issue warnings to the driver accordingly. If the TPMS module expects the spare tire to be fitted with a tire pressure sensor and it does not, the module will not show a fault to the driver, however a fault code will be stored in the TPMS module.

If the spare tire is being monitored and the driver replaces a flat 'running' tire with the spare tire, the module will not continually warn the driver that the original flat tire (now in the spare position) is flat. This prevents distraction of the driver by constant pressure warnings being issued. The driver is reminded by a message displayed for 20 seconds at each ignition on cycle that the spare tire is flat.

System Operation

Each time the vehicle is driven, the TPMS module transmits a Low Frequency (LF) (125 KHz) signal to each initiator in turn. This is received by the tire pressure sensor which transmits a Radio Frequency (RF) (315 or 433 MHz depending on market) signal to the module. This signal contains coded data which corresponds to sensor identification, air pressure, air temperature and acceleration data.

The system enters 'parking mode' after the vehicle speed has been less than 12.5 mph (20 km/h) for 12 minutes. In parking mode the tire pressure sensors transmit a coded signal to the module once every 13 hours. If the tire pressure decreases by more than 1 lbf/in² (0.6 bar) the sensor will transmit more often if pressure is being lost.

The spare tire sensor transmits a signal every 13 hours in the same manner as the road wheels when in parking mode. If the tire pressure decreases by more than 1 lbf/in² (0.6 bar) the sensor will transmit more often if pressure is being lost.

As each wheel responds to the LF signal from the TPMS module, it is assigned a position on the vehicle and is monitored for the remainder of that drive cycle in that position.

When the vehicle has been parked for more than 15 minutes and then driven at a speed of more than 12.5 mph (20 km/h), the initiators fire in turn for 6 seconds on all except NAS vehicles or for 18 seconds on NAS only vehicles in the following order:

- Front left
- 6 second pause (for the TPMS module to detect a response from the tire pressure sensor)
- Front right
- 6 second pause
- Rear right
- 6 second pause
- Rear left
- 6 second pause.

Each tire pressure sensor responds in turn so the module can establish the sensor positions at the start of the drive cycle. This process is repeated up to three times but less if the sensor positions are already known in the module. The process is known as 'Auto Location' and takes 3 to 4 minutes on all except NAS vehicles and 7 to 8 minutes on NAS vehicles to complete. During this period the tire sensors transmit at regular intervals, once every 5 seconds on all except NAS vehicles and once every 15 seconds on NAS vehicles. For the remainder of the drive cycle the tire sensors transmit once every 60 seconds or if a change in tire pressure is sensed until the vehicle stops and the system returns to parking mode.

Once the wheel position is established, the initiators stop firing a signal and do not fire again until the vehicle has been parked for more than 15 minutes. The signal transmissions from each wheel sensor continue at 1 minute intervals whilst the vehicle is being driven. This transmission is to monitor the tire pressure. There are two levels of warning; amber warning indicator illuminated at 25% deflation and an appropriate message displayed in the instrument cluster message center at 35% deflation. The message center will also display additional information about the position of the affected wheel(s).

Initiator

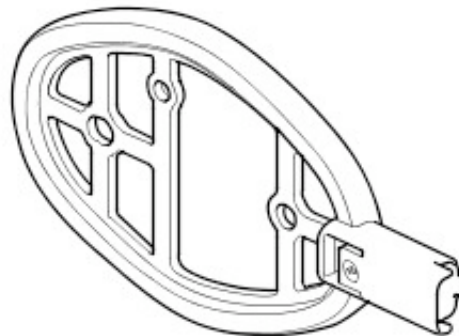

E45552

The initiators are located near the front of the front wheel arches and near the rear of the rear wheel arches and are secured with two screws. The TPMS has four initiators. Each initiator has a connector which connects with the body harness.

The initiator is a passive, Low Frequency (LF) transmitter. Each initiator provides an auto-location feature to identify tire positions on the vehicle and transmit that data to the TPMS module.

The TPMS module energises each initiator in turn using LF drivers. The corresponding tire pressure sensor detects the resulting LF transmission and responds by initiating an RF transmission of its data. This data is received by the TPMS module internal RF antenna. The module can then determine which sensor is transmitting and its location on the vehicle.

Tire Pressure Sensor

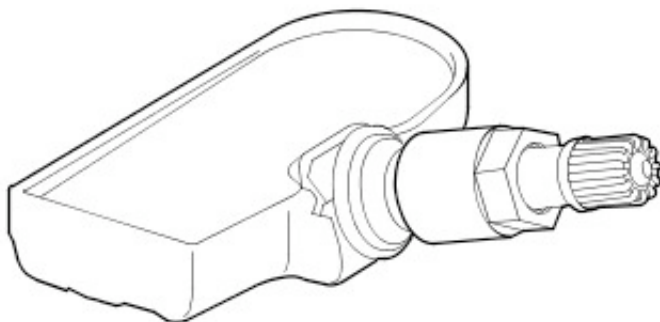

E45553

The TPMS system uses 'active' tire pressure sensors which are mounted on each wheel, inside the tire cavity. The sensor is retained in position by the valve attachment to the wheel structure. The sensors transmit their RF signals at either 315 MHz or 433 MHz dependent on market requirements.

The sensors periodically measure the pressure and temperature of the air inside the tire. Pressure and temperature measurements are transmitted periodically to the RF receiver in the vehicle.

The tire pressure sensors are self-contained units which have no electrical connections into or out of the sensor.

The care points detailed in 'Tire Changing' in this chapter must be followed to avoid damage to the sensor. If the sensor is replaced, the nut, seal and washer must also be replaced and the sensor tightened to the correct torque value as given in the Service Repair manual.

The RF transmission from the sensor contains a unique identification code in its transmission data, so that the TPMS module can identify the tire on the vehicle. If the sensor is replaced on a 'running' wheel, the new sensor identification will be learnt when the vehicle is first driven at a speed of more than 12.5 mph (20 km/h) for 15 minutes. If a new sensor is fitted to the spare wheel, the identification for that sensor must be programmed into the TPMS module using T4 or that wheel will not be monitored. The code is provided on a label with the complete wheel and tire assembly when new and is also printed on the casing of each sensor.

The replacement spare wheel may also be programmed to the vehicle by using it as a 'running' wheel for 15 minutes at more than 12.5 mph (20 km/h), then replacing it to the spare wheel position.

In order to conserve battery power, the tire sensor module uses different transmission rates when the wheel is stationary or moving. The wheel speed required to change between the stationary and moving transmission rates is very low to allow for the requirement for slow off-road driving.

TPMS Switch

NOTE:

The TPMS switch is not fitted to NAS vehicles. NAS vehicles do not have the option to select target pressure modes.

The TPMS switch is a non-latching push button switch which is located in the center console switch pack, adjacent to the DSC switch.

The TPMS switch is used by the driver to set the required target pressures for the vehicle, i.e. 'normal load' or 'high load'. The switch is used to toggle between the two modes.

The TPMS switch has a status LED, located in the face of the switch, which informs the driver when the 'normal load' or 'high load' pressures are set. When 'normal load' mode is set, the LED is illuminated. When 'high load' mode is set, the LED is extinguished.

The status LED has two-stage illumination, providing day or night time illumination levels. The illumination level is determined by the TPMS module, based on data received via the vehicle CAN interface.

The switch is used to change between the modes as required. The ignition switch must be in position II. If the TPMS is in the 'normal load' mode, pressing and holding the switch for 4 seconds will change the target pressures to 'high load' mode. The LED will be extinguished, the message center in the instrument cluster will flash 'Tyre Pressure Monitoring Heavy Load Mode' for 5 seconds. This setting will remain until deselected by the driver.

To change from 'high load' mode to 'normal load' mode, the ignition switch must be in position II and the switch must be pressed and held for 4 seconds. This will change the target pressures from 'high load' mode to 'normal load' mode. The switch LED will illuminate and the instrument cluster message center will display 'Tyre Pressure Monitoring Light Load Mode' for 5 seconds.

Instrument Cluster Indications

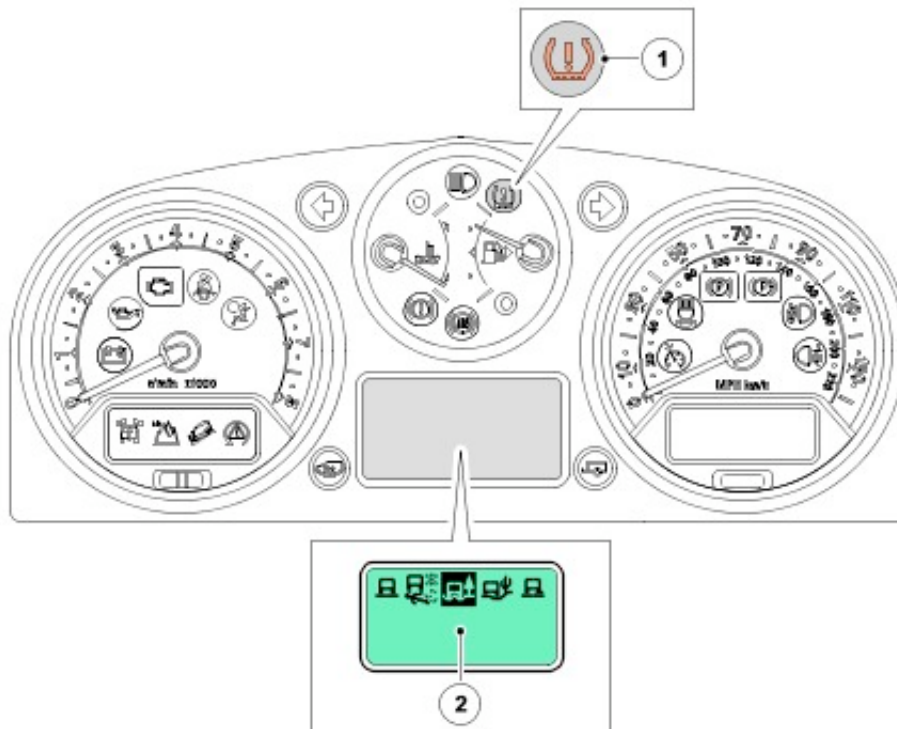

E56257

Item	Part Number	Description
1		Amber warning indicator
2		Message center

The warning indications to the driver are common on all vehicles fitted with TPMS. Warnings are conveyed by an amber LED warning indicator and a text message displayed in the message center.

The warning indicator and message center are driven by CAN messages from the TPMS module. The warning indicator is illuminated by the cluster software for 3 seconds when the ignition is switched to position II for a bulb check.

NOTE:

If the vehicle is not fitted with the TPMS, the warning indicator will not illuminate at any time.

When the TPMS module transmits a warning indicator on signal, this may also be accompanied by a chime from the instrument cluster sounder.

The following table shows the warning indicator functionality for given events.

Event	Instrument Cluster Indications
Minor warning threshold reached in any 'running' tire	Amber LED illuminated. 'CHECK TYRE PRESSURES' message displayed.
Minor warning threshold reached in spare tire (if fitted)	Amber LED illuminated for 20 seconds then extinguished. At next and subsequent ignition cycles Amber LED illuminated for 20 seconds then

None (all tires)	extinguished. 'CHECK SPARE TYRE PRESSURE' message displayed.
Major warning threshold reached in any 'running' tire	'XX TYRE PRESSURE VERY LOW' message displayed. Sounder activated once when message is displayed.
Major warning threshold reached in more than one 'running' tire	'TYRE PRESSURES VERY LOW' message displayed. Sounder activated once when message is displayed. Sounder activated once before Amber LED illuminated, message displayed and vehicle speed increased from 0 to 37 mph (0 to 60 km/h).
Over-pressure threshold reached in any 'running' tire with 'normal load' mode set	'XX TYRE PRESSURE TOO HIGH' message displayed
Over-pressure threshold reached in more than one 'running' tire with 'normal load' mode set	'TYRE PRESSURES TOO HIGH' message displayed
Any 'running' or 'spare' tire pressure sensor battery low	No indication (Fault code stored on TPMS module)
TPMS Fault	Amber LED illuminated. Amber LED illuminated at next and subsequent ignition on cycle. Sounder activated on initial LED illumination. 'TYRE PRESSURE MONITORING SYSTEM FAULT' message displayed.
One TPMS wheel sensor fault	Amber LED illuminated. Amber LED illuminated at next and subsequent ignition on cycle. Sounder activated on initial LED illumination. 'XX TYRE PRESSURE NOT MONITORED' message displayed.
More than one TPMS wheel sensor fault	Amber LED illuminated. Amber LED illuminated at next and subsequent ignition on cycle. Sounder activated on detection of each additional wheel sensor fault event. 'TYRE PRESSURE MONITORING SYSTEM FAULT' message displayed.
TPMS switch pressed for 4 seconds to set 'Normal Load' operation when engine is not running and the ignition switch is in position II	TPMS switch status LED illuminated. 'TYRE PRESSURE MONITORING LIGHT LOAD MODE' message displayed for 3 seconds.
TPMS switch pressed for 4 seconds to set 'High Load' operation when engine is not running and the ignition switch is in position II	TPMS switch status LED is extinguished. 'TYRE PRESSURE MONITORING HEAVY LOAD MODE' message is displayed for 3 seconds.

NOTE:

'XX' is the tire position on the vehicle, e.g. FL (front left), FR (front right), RL (rear left) or RR (rear right).

TPMS Module Inputs and Outputs

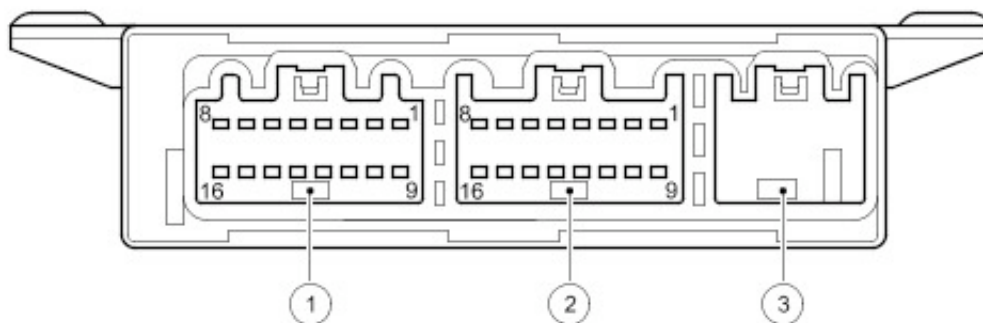

E45555

Item	Part Number	Description
1		Connector C2447
2		Connector C1537
3		Not used

Two connectors provide the interface between the TPMS module and the external TPMS components. The third connector aperture on the TPMS module is not used.

The following tables show the details of the signals or electrical supplies on each connector pin.

Connector C1537

Pin No.	Description	Input/Output
1	Not used	-
2	CAN LOW - IN	Input/Output
3	CAN HIGH - IN	Input/Output
4	Not used	-
5	TPMS Switch LED Drive	Output
6	Not used	-
7	TPMS Switch	Input
8	Ignition 12V supply	Input
9	Not used	-
10	CAN LOW - OUT	Input/Output
11	CAN HIGH - OUT	Input/Output
12	Ground	Input
13 to 15	Not used	-
16	12V Permanent battery supply	Input

Connector C2447

Pin No.	Description	Input/Output
1 to 4	Not used	-
5	Rear LH initiator - Signal positive (+)	Output
6	Rear LH initiator - Signal negative (-)	Output
7	Rear RH initiator - Signal positive (+)	Output
8	Rear RH initiator - Signal negative (-)	Output
9 to 12	Not used	-
13	Front LH initiator - Signal positive (+)	Output
14	Front LH initiator - Signal negative (-)	Output
15	Front RH initiator - Signal positive (+)	Output
16	Front RH initiator - Signal negative (-)	Output

Controller Area Network (CAN)

The TPMS module sends and receives a number of digital messages via the medium speed CAN. The received messages are used for the operation of the TPMS. The transmitted messages comprise of TPMS status and requests to the instrument cluster to illuminate warnings indicators and/or display messages in the message center.

Received Messages

The TPMS module receives the messages shown in the following table.

Message	Transmitted By
Vehicle speed	ABS module
External ambient temperature - corrected	ATC module
Side lamp status	CJB
Ignition switch status	CJB
Odometer value	Instrument cluster
Minute counter	Instrument cluster
Vehicle voltage level	Instrument cluster
Engine crank relay status	ECM
Diagnostic physical request	T4
Diagnostic functional request	T4
Engine running status	ECM
Master car configuration identification	Instrument cluster
Car configuration parameters	Instrument cluster

Transmitted Messages

The TPMS module transmits the messages shown in the following table.

Message	Received By
TPMS diagnostic response	T4
TPMS yellow warning indicator request at 25% tire deflation	Instrument cluster
TPMS audible alert	Instrument cluster
TPMS message display request	Instrument cluster

Diagnostics

The TPMS module has a diagnostic connection via the medium speed CAN to enable system status and faults to be retrieved using T4.

Additionally, an on-board diagnostic routine within the TPMS module constantly monitors the system and alerts the driver to system faults by illuminating the amber warning indicator, emitting a tone from the instrument cluster sounder and/or displaying a message in the instrument cluster message center.

Fault Detection

If a sensor fails, the amber warning indicator in the instrument cluster will be illuminated. A message 'XX Tyre Pressure Not Monitored' will be displayed in the message center in addition to the amber warning indicator.

If more than one sensor fails or the TPMS module develops a fault, the amber warning indicator will be illuminated. A message 'Tyre Pressure Monitoring System Fault' will be displayed in the message center in addition to the amber warning indicator. This fault could also be caused if RF interference near the vehicle affects the system signal reception. When the interference has ceased, the fault will be automatically cancelled and the TPMS will operate normally.

If a tire pressure sensor battery voltage becomes low, the sensor transmits a message to the TPMS module. The module stores the low battery condition as a fault flag in its memory with no other visual warnings displayed. If the battery fails, the sensor will stop transmitting and the TPMS module will transmit a message to display 'FL Tyre Not Being Monitored' for example in the message center. The dealer should interrogate the TPMS module using T4 for the fault flag to determine the cause of the message. If the battery has failed the sensor must be replaced and the stored fault flags removed using T4.

The TPMS module will learn the identification of the new sensor when the vehicle is driven. If the replaced sensor is fitted to the spare wheel (if fitted), its identification must be manually programmed into the module using T4 or by using it as a 'running' wheel for 15 minutes at more than 12.5 mph (20 km/h), then replacing it to the spare wheel position.

CONTROL DIAGRAM

NOTE:

A = Hardwired; B = RF Transmission; N = Medium Speed CAN Bus

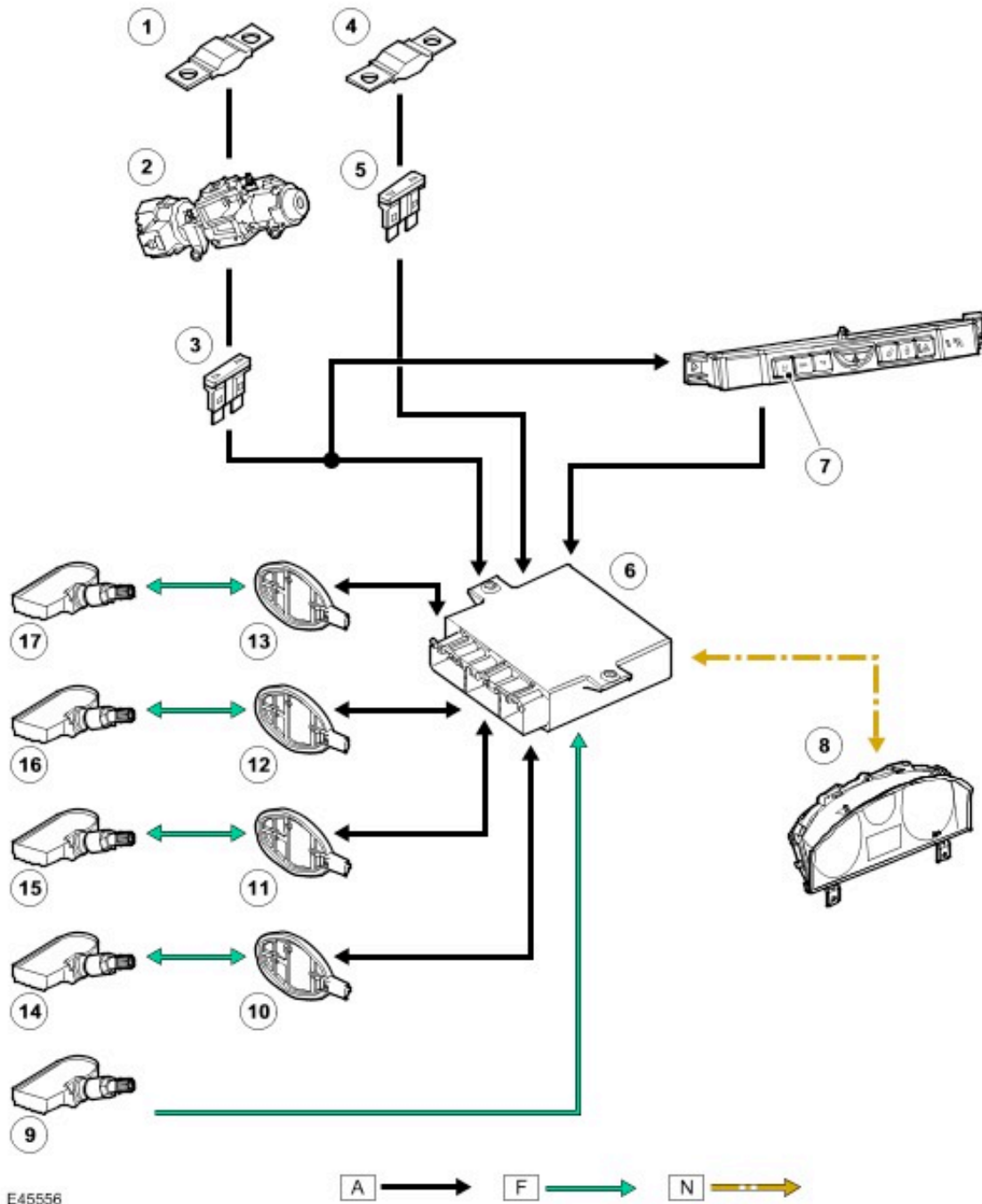

E45556

Item	Part Number	Description
1		Fusible link 17E (50A)
2		Ignition switch
3		Fuse 36P (5A)

4		Fusible link 11E (30A)
5		Fuse 32P (10A)
6		TPMS module
7		TPMS switch and LED
8		Instrument cluster
9		Tire pressure sensor - spare (if fitted)
10		Initiator - Rear right hand
11		Initiator - Rear left hand
12		Initiator - Front right hand
13		Initiator - Front left hand
14		Tire pressure sensor - Rear right hand
15		Tire pressure sensor - Rear left hand
16		Tire pressure sensor - Front right hand
17		Tire pressure sensor - Front left hand