

Front Shock Absorber and Air Spring Assembly (60.21.01.99)

Removal

NOTE:

Only the air spring being removed needs to be depressurised.

1



WARNING: Do not work on or under a vehicle supported only by a jack. Always support the vehicle on safety stands.

Raise and support the vehicle.

2 . Remove the fender splash shield.

For additional information, refer to [Fender Splash Shield \(76.10.48\)](#)

3 . Using T4, depressurize the air suspension.

For additional information, refer to [Air Suspension System Depressurize and Pressurize \(60.50.38\)](#)

4 . Disconnect the shock absorber and air spring assembly from the lower arm.

 Remove the nut and bolt.

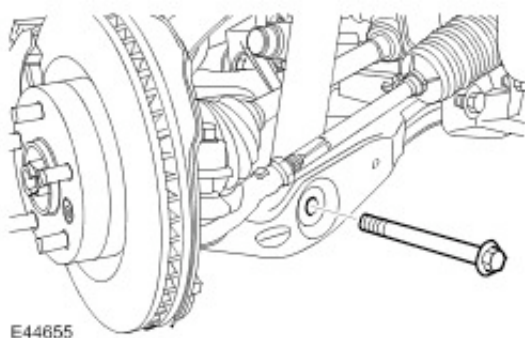

5 . Release the heat shield for access to the shock absorber and air spring assembly upper mounting inner nut.

 Remove the nut and two bolts.

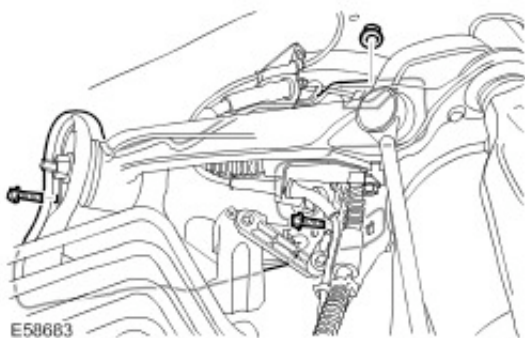

6 . Release the shock absorber and air spring assembly.

 Remove the three retaining nuts.

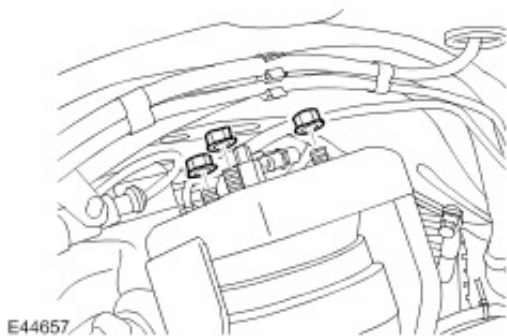

- 7.  **CAUTION: Always plug any open connections to prevent contamination.**

Release the shock absorber and air spring assembly and disconnect the air line.

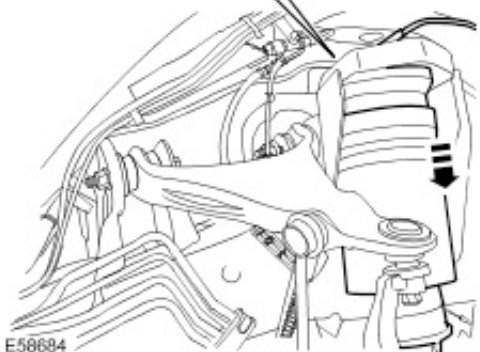

- 8. Remove the shock absorber and air spring assembly.

- 9.  **CAUTION: Visually inspect the air line ends for damage or wear. Repair or replace the air line as necessary.**

Remove the Voss connector from the air line.

 Remove and discard the collet and the union.

Installation

- 1.  **CAUTION: Make sure the new Voss connector is installed and fully tightened with the alignment**

plug installed.

NOTE:

New air suspension components are supplied with new Voss connectors tightened to the correct torque. Do not install a new voss connector if a new component is being installed.

Install a new Voss connector to the air spring.

 Tighten to 3.5 Nm (2.6 lb.ft)

2 . Install the shock absorber and air spring assembly.

 Make sure the shock absorber and air spring assembly top mounting to body mating faces are clean.

 Connect the air line into the Voss connector.

 Fit the nuts and tighten to 63 Nm (46 lb.ft).

 Pull on the air line to make sure it is fully installed into the Voss connector.

3 . Secure the heat shield.

 Install the nut and two bolts and tighten to 10 Nm (7 lb.ft).

4 . Connect the shock absorber and air spring assembly to the lower arm.

 Tighten the nut and bolt to 300 Nm (221 lb.ft).

5 . Using T4, pressurize the air suspension.

For additional information, refer to [Air Suspension System Depressurize and Pressurize \(60.50.38\)](#)

6 . Install the fender splash shield.

For additional information, refer to [Fender Splash Shield \(76.10.48\)](#)