

Air Leaks

Special Service Tools



Hose Cutter
204-494 (LRT 60-002)

1.



CAUTION: Any leak detection spray used must have a corrosion inhibitor, and must not cause damage to paintwork, plastics, metals or plastic lines.

NOTE:

The recommended leak detection spray is GOTEC LDS, Landrover part number STC 1090.

The recommended leak detection spray should be used to identify any suspected leaks. This procedure should also be used where any of the air suspension components have been disturbed.

2. Clean around the area of the suspected air leak.

3. Using the recommended leak detection spray, spray around all of the air suspension components, working systematically until the source of the air leak has been found.

4. If any of the air suspension components are found to be leaking e.g. air spring, compressor, reservoir or a solenoid valve block, repair is effected by replacement only.

5. Using T4, depressurize the air suspension system.
[Air Suspension System Depressurize and Pressurize \(60.50.38\)](#)

6.



CAUTION: Different air lines in the air suspension system have different material properties and wall thicknesses. It is important, in order to prevent subsequent air line failure, that the new air line material and wall thicknesses are identical to those of the air line being removed.



CAUTION: Replacement air line must be cut from a new air line with the equivalent Land Rover part number as the one being replaced. Do not use air line cut from a roll or coil.



CAUTION: Any existing heatsleeves and abrasion sleeves must be replaced as part of the repair.



CAUTION: Air line connectors should be positioned in areas away from heat sources such as the exhaust system, and away from any section of air line with a heat shield installed.



CAUTION: Do not trim air line ends. If the end of the air line is damaged, the air line must be cut and a new section added using a Land Rover approved air line connector, or the air line must be renewed completely.

NOTE:

Air lines must only be cut using either Hose cutter 204-494 (LRT 60-002), available from SPX LTD or Hose cutter YA1000A, available from Snap-On Tools. Make sure the cut air line end is free from damage or burrs.

NOTE:

Only Land Rover approved air lines have been tested to the correct pressure and temperature specifications.

NOTE:

Only the Land Rover approved air line connector, RYC500210, has been tested to the correct pressure and temperature specifications.

NOTE:

If the markings or tape adjacent to the air line connections are removed when cutting air lines, the cut end of the air line must be clearly marked with a suitable colored tape or paint mark.

If the source of the air leak is found to be an air line connection, renew the Voss connector and, if required, the end of the air line. Using the special tool, cut off the damaged end of the air line and replace with new Land Rover approved air line and air line connectors as required.

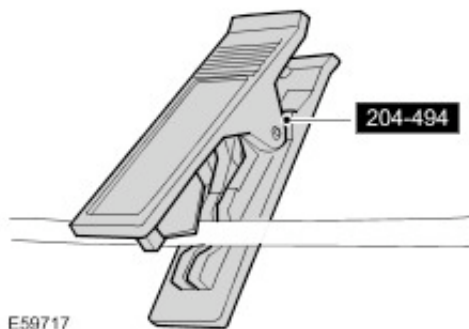

7. If the source of the air leak is found to be in a section of air line, either; renew the air line, or, using the special tool, cut out the damaged section of air line and replace with new Land Rover approved air line, and air line connectors, as required.

8. **NOTE:**

If the repair has been unsuccessful repeat the above steps until the air leak is rectified.

Using T4, pressurize the air suspension system.

[Air Suspension System Depressurize and Pressurize \(60.50.38\)](#)